

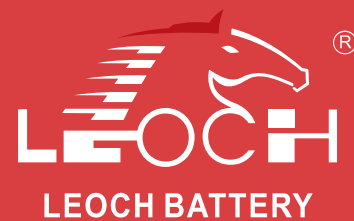

# LHR Series-High Rate

## LHR12360W(12V360W)



### Specifications

Rated Voltage	12V		
Nominal Rate( $W_{15}, 1.67V/cell$ )	360W/cell		
Nominal Capacity( $C_{10}, 1.80V/cell$ )	100Ah		
Dimension	Length	330±2mm (13.0 inches)	
	Width	173±2mm (6.81 inches)	
	Container Height	213±2mm (8.39 inches)	
	Total Height	216±2mm (8.50 inches)	
Approx Weight	29.4kg (64.8 lbs)		
Terminal	M8		
Container Material	ABS: UL 94 HB or V-0		
Rated Capacity(25°C)	100.0 Ah	C10(10.0A, 1.80V/cell)	
	96.0 Ah	C8(12.0A, 1.80V/cell)	
	89.0 Ah	C5(17.8A, 1.75V/cell)	
	77.1 Ah	C3(25.7A, 1.75V/cell)	
	66.0 Ah	C1(66.0A, 1.60V/cell)	
Max. Discharge Current	1000A (5s)		
Internal Resistance(25°C)	Approx 3.5mΩ		
Operating Temp. Range	Discharge	-20 ~ 55°C (-4 ~ 131°F)	
	Charge	-20 ~ 40°C (-4 ~ 104°F)	
	Storage	-15 ~ 50°C (5 ~ 122°F)	
Nominal Operating Temp. Range	25±3°C (77±5°F)		
Max.Charging Current(25°C)	25.0A		
Charge voltage(25°C)	Float	2.25 ~ 2.30V/cell	-3mV/cell/°C
	Equalization	2.30~2.40V/cell	-4mV/cell/°C
Effect of temp. to Capacity	40°C (104°F)	106%	
	25°C (77°F)	100%	
	0°C (32°F)	86%	
Self Discharge	≤3%/month @ 25°C		

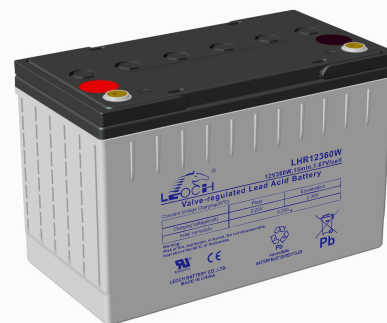

### Layout

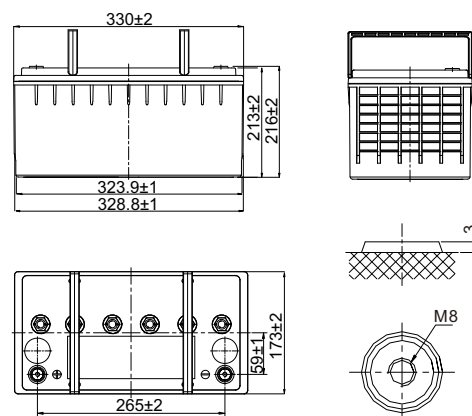

### Constant Current Discharge (Amperes) at 25 °C (77°F)

F.V/Time	5min	10min	15min	20min	30min	45min	1h	1.5h	2h	3h	4h	5h	8h	10h
1.85V/cell	278.5	206.5	164.2	116.7	87.6	65.5	52.8	37.3	31.5	23.8	19.4	16.6	11.7	9.76
1.80V/cell	310.4	230.1	183.0	126.3	94.4	69.6	55.9	39.5	33.2	24.8	20.3	17.2	12.0	10.0
1.75V/cell	323.9	240.1	191.0	138.6	102.2	74.0	59.3	41.8	34.7	25.7	21.1	17.8	12.2	10.1
1.70V/cell	328.0	243.1	193.4	148.2	107.2	78.4	62.0	43.7	36.0	26.5	21.6	18.1	12.4	10.2
1.67V/cell	333.0	246.8	196.4	156.3	112.0	80.9	64.2	45.2	37.1	27.3	22.1	18.4	12.6	10.3
1.60V/cell	338.1	250.6	199.3	162.3	116.0	83.2	66.0	46.3	37.7	27.8	22.4	18.7	12.7	10.5

### Constant Power Discharge (Watts/cell) at 25 °C (77°F)

F.V/Time	5min	10min	15min	20min	30min	45min	1h	1.5h	2h	3h	4h	5h	8h	10h
1.85V/cell	456.0	378.5	301.1	227.4	172.5	130.1	105.6	76.0	63.3	48.0	39.3	33.7	23.9	20.0
1.80V/cell	515.4	421.8	335.6	243.9	184.9	137.6	111.3	79.9	66.5	49.9	41.0	34.9	24.5	20.5
1.75V/cell	555.5	440.2	350.2	264.9	198.6	145.5	117.6	84.4	69.3	51.6	42.5	36.0	24.9	20.6
1.70V/cell	590.3	445.7	354.5	280.4	206.6	153.3	122.3	87.7	71.5	53.1	43.3	36.4	25.2	20.8
1.67V/cell	612.0	452.5	360.0	292.3	214.0	157.1	125.7	90.1	73.4	54.5	44.2	37.0	25.5	20.9
1.60V/cell	620.8	459.4	365.5	299.0	219.0	159.7	128.2	91.7	73.9	55.0	44.6	37.4	25.6	21.2



# LHR Series-High Rate

## LHR12360W(12V360W)

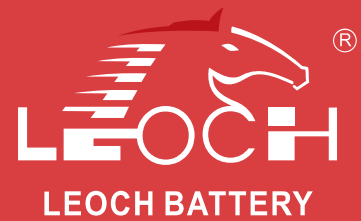

### Applications

- UPS
- Hospitals & Testing Laboratories
- Emergency Power Supply
- Banks & Financial Markets
- Industrial Process Control Facilities
- Data & Network Operation Centers

### General Features

- High quality AGM separator: extend cycle life and prevent micro short circuit
- PbCaSn alloy for plate grids: less gassing, less self-discharging
- Unique vent valve design: reduce water losing and prevent air/spark going inside

### Standards

- Compliance with IEC 60896 and YD/T 3427 standards
- CE, UL, TLC Certified
- Manufactured in Leoch@IATF16949, ISO 45001, ISO 9001 and ISO 14001 certified production facilities

### Discharge Characteristics

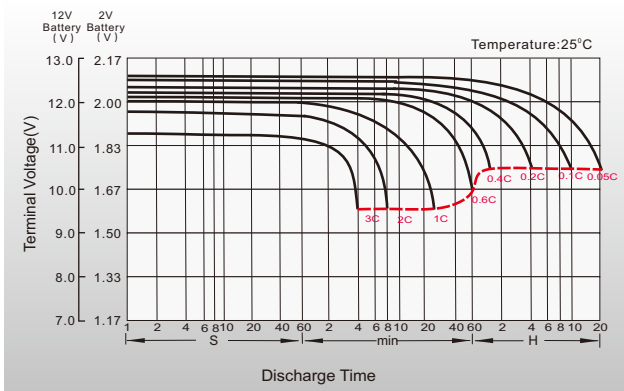

### Float Charging Characteristics

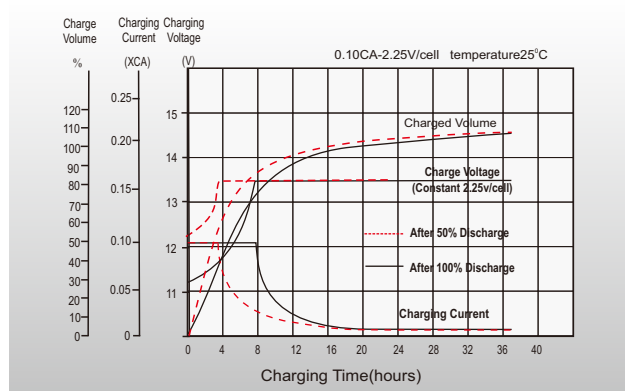

### Temperature Effects in Relation to Battery Capacity

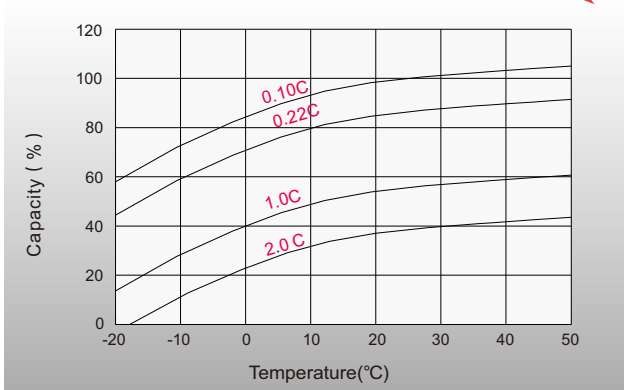

### Effect of Temperature on Long Term Float Life

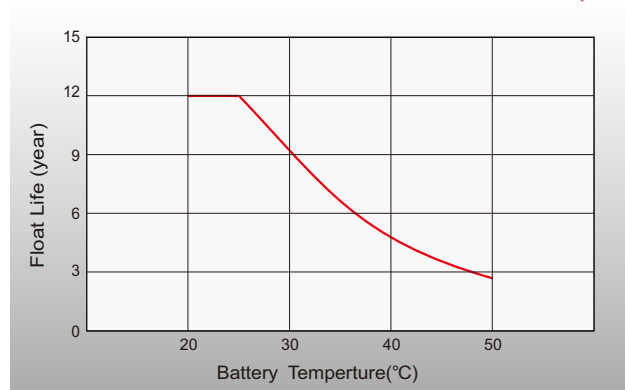

## Sales Offices Worldwide

#### China Sales Office

5th Floor, Xinbaohui Bldg., Nanhai Blvd.,  
Nanshan, Shenzhen, China. 518052  
Tel: +86-755-86036060 (100 lines)  
Fax: +86-755-26067269  
E-mail: export@leoch.com

#### North America Sales Office

19751 Descartes  
Foothill Ranch, CA 92610, USA  
Tel: 949-588-5853  
Fax: 949-588-5966  
E-mail: sales@leoch.us  
Http://www.leoch.us

#### HongKong Sales Office

Workshop C, 33/F, TML Tower, No. 3 Hoi Shing Road,  
Tsuen Wan, New Territories, Hong Kong  
Tel: +852 35786666  
Fax: +44 1452 690125  
E-mail: sales.hk@leoch.com

#### UK Sales Office

9B Wheatstone Court, Waterwells, Business Park,  
Gloucester, GL2-2AQ, UK United Kingdom  
Tel: +44(0) 1452 729428 / 1452 729696  
Fax: +44 1452 690125  
E-mail: Sales.Europe@leoch.com  
Http://www.leoch.eu

#### Singapore Sales Office

No. 1 Tech Park Crescent,  
Singapore 638131  
Tel: +65 68636078  
Fax: +65 6863 6079  
Email: sales.sg@Leoch.com

#### EMEA Sales Office

1 Deligiorgi St., 121 31 Athens,  
Greece  
Tel: +30 210 5760318 (2 lines)  
E-mail: support\_EMEA@leoch.com  
Http://www.leoch.eu

#### Australia Sales Office

2/29 Tarlington Place, Smithfield, NSW 2164  
Australia  
Tel: 02 9756 0950  
E-mail: sales.au@leoch.com

#### India Sales Office

Shed no. A-53(b), 2nd Stage of Peenya Industrial Area,  
Bangalore North Taluk, Bangalore-560058, India  
Tel: +91-80-23440018/23440019  
Fax: +91-80-23440017  
E-mail: indiasales@leoch.com



[Http://www.leoch.com](http://www.leoch.com)

© 1999-2022 LEOCH. All rights reserved.

Trademarks and logos are the property of LEOCH and its affiliates unless otherwise noted.  
Subject to revisions without prior notice.

Publication No.: LB-LHR12360W-PD-EN-V1.4-202204