



# LHR Series-High Rate

## LHR12255W(12V255W)



### Specifications

Rated Voltage	12V		
Nominal Rate ( $W_{15}, 1.67V/cell$ )	255W		
Nominal Capacity( $C_{10}, 1.80V/cell$ )	70Ah		
Dimension	Length	348±2mm (13.70 inches)	
	Width	167±2mm (6.57 inches)	
	Container Height	178±2mm (7.01 inches)	
	Total Height	178±2mm (7.01 inches)	
Approx. Weight	21.6 Kg (47.6 lbs)		
Terminal	M6		
Container Material	ABS: UL 94 HB or V-0		
Rated Capacity (25°C)	70.0 Ah	(10hr, 7.00A, 1.80V/cell)	
	67.2 Ah	(8hr, 8.40A, 1.80V/cell)	
	61.5 Ah	(5hr, 12.3A, 1.75V/cell)	
	55.8 Ah	(3hr, 18.6A, 1.75V/cell)	
	48.0 Ah	(1hr, 48.0A, 1.67V/cell)	
Max. Discharge Current	900A		
Internal Resistance (25°C)	Approx. 6.6mΩ		
Operating Temp. Range	Discharge	-20 ~ 55°C (-4 ~ 131°F)	
	Charge	-20~ 40°C (-4 ~ 104°F)	
	Storage	-15 ~ 50°C (5 ~ 122°F)	
Nominal Operating Temp. Range	25±3°C (77±5°F)		
Max. Charging Current(25°C)	17.5A		
Charge voltage(25°C)	Charge voltage	Temp. Coefficient	
	Float	2.25 ~2.30V/cell	-3mV/cell/°C
	Equalization	2.30~2.40V/cell	-4mV/cell/°C
Effect of temp. to Capacity	40°C (104°F)	106%	
	25°C (77°F)	100%	
	0°C (32°F)	86%	
Self Discharge	≤3%/month @ 25°C		



### Layout

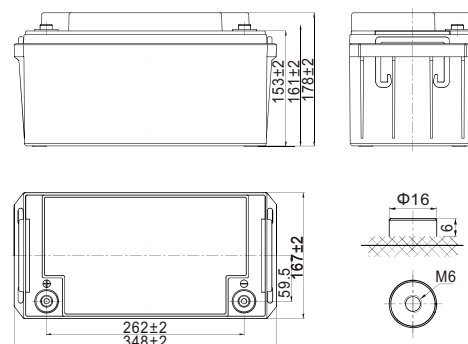

### Constant Current Discharge (Amperes) at 25 °C (77° F)

F.V/Time	5min	10min	15min	20min	30min	45min	1h	1.5h	2h	3h	4h	5h	8h	10h
1.85V/cell	156.1	116.5	97.1	81.6	62.7	46.8	39.5	29.6	23.7	16.7	13.3	11.1	7.80	6.60
1.80V/cell	182.0	137.4	112.9	94.0	70.9	52.3	43.7	32.4	25.8	18.1	14.3	12.0	8.40	7.00
1.75V/cell	198.6	147.3	119.4	98.6	74.1	54.4	45.4	33.5	26.6	18.6	14.7	12.3	8.60	7.10
1.70V/cell	215.1	157.1	126.2	103.8	77.3	56.5	47.0	34.7	27.5	19.1	15.1	12.5	8.70	7.20
1.67V/cell	224.5	162.9	130.2	106.7	79.3	57.8	48.0	35.3	27.9	19.4	15.3	12.7	8.80	7.30
1.60V/cell	247.5	176.3	139.5	113.6	83.8	60.8	50.3	36.8	29.1	20.1	15.8	13.1	9.00	7.40

### Constant Power Discharge (Watts/cell) at 25 °C (77° F)

F.V/Time	5min	10min	15min	20min	30min	45min	1h	1.5h	2h	3h	4h	5h	8h	10h
1.85V/cell	301.4	225.9	189.1	159.4	135.2	98.9	78.6	57.8	46.4	35.1	28.0	23.5	16.6	13.9
1.80V/cell	349.5	265.3	219.2	183.1	142.6	105.7	84.4	61.0	49.2	36.7	30.1	25.2	17.7	14.8
1.75V/cell	384.2	283.0	232.7	191.0	147.8	109.2	86.9	64.0	51.4	38.0	30.7	25.7	18.0	15.0
1.70V/cell	409.3	304.2	246.5	203.9	152.9	112.4	89.5	66.4	52.8	39.1	31.4	26.2	18.3	15.2
1.67V/cell	418.3	312.9	255.0	209.4	158.6	114.4	90.9	67.3	53.5	39.8	31.7	26.5	18.5	15.4
1.60V/cell	424.6	331.7	265.9	223.3	162.6	119.0	94.5	69.3	55.1	40.4	32.6	27.1	18.9	15.6



# LHR Series-High Rate

## LHR12255W(12V255W)



### Applications

- UPS
- Hospitals & Testing Laboratories
- Emergency Power Supply
- Industrial Process Control Facilities
- Banks & Financial Markets
- Data & Network Operation Centers

### General Features

- High quality AGM separator: extend cycle life and prevent micro short circuit
- PbCaSn alloy for plate grids: less gassing, less self-discharging
- Unique vent valve design: reduce water losing and prevent air/spark going inside

### Standards

- Compliance with IEC 60896 standards
- Classified as "Long Life" according to Eurobat
- CE, UL, IEC Certified
- Manufactured in Leoch@IATF16949, ISO 45001, ISO 9001 and ISO 14001 certified production facilities

### Discharge Characteristics

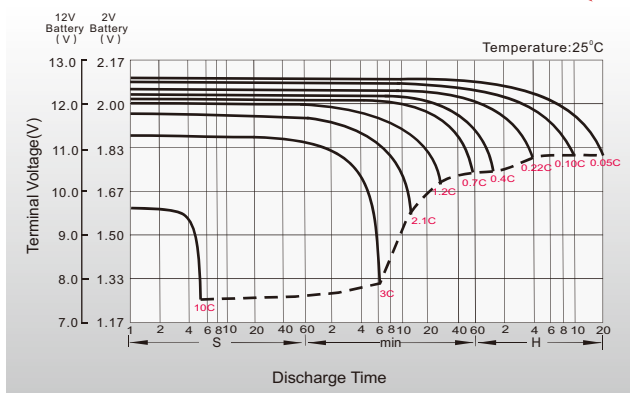

### Float Charging Characteristics

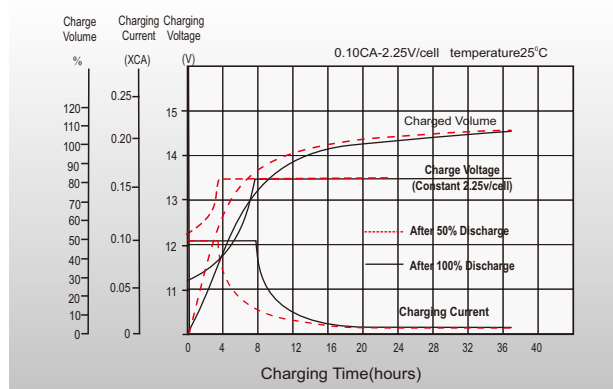

### Temperature Effects in Relation to Battery Capacity

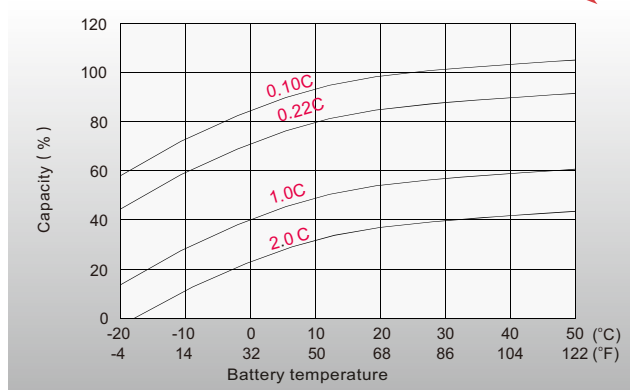

### Effect of Temperature on Long Term Float Life

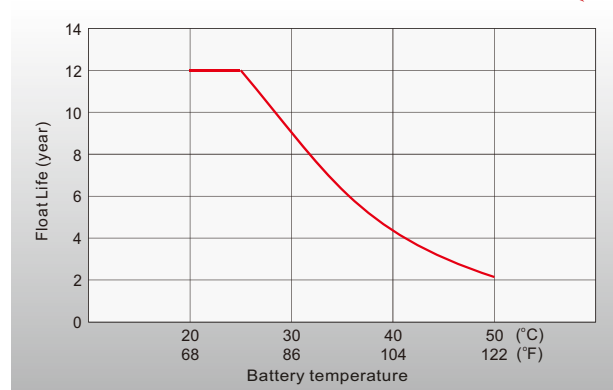

## Sales Offices Worldwide

#### China Sales Office

5th Floor, Xinbaohui Bldg., Nanhai Blvd.,  
Nanshan, Shenzhen, China. 518052  
Tel: +86-755-86036060 (100 lines)  
Fax: +86-755-26067269  
E-mail: export@leoch.com

#### HongKong Sales Office

Workshop C, 33/F, TML Tower, No. 3 Hoi Shing Road,  
Tsuen Wan, New Territories, Hong Kong  
Tel: +852 35786666  
Fax: +44 1452 690125  
E-mail: sales.hk@leoch.com

#### Singapore Sales Office

No. 1 Tech Park Crescent,  
Singapore 638131  
Tel: +65 68636078  
Fax: +65 6863 6079  
Email: sales.sg@Leoch.com

#### Australia Sales Office

2 /29 Tarlington Place, Smithfield. NSW 2164  
Australia  
Tel: 02 9756 0950  
E-mail: sales.au@leoch.com

#### North America Sales Office

19751 Descartes  
Foothill Ranch, CA 92610, USA  
Tel: 949-588-5853  
Fax: 949-588-5966  
E-mail: sales@leoch.us  
Http:// www.leoch.us

#### UK Sales Office

9B Wheatstone Court, Waterwells, Business Park,  
Gloucester, GL2-2AQ, UK United Kingdom  
Tel: +44(0) 1452 729428 / 1452 729696  
Fax: +44 1452 690125  
E-mail: Sales.Europe@leoch.com  
Http:// www.leoch.eu

#### EMEA Sales Office

1 Deligiorgi St., 121 31 Athens,  
Greece  
Tel: +30 210 5760318 (2 lines)  
E-mail: support\_EMEA@leoch.com  
Http:// www.leoch.eu

#### India Sales Office

Shed no. A-53(b), 2nd Stage of Peenya Industrial Area,  
Bangalore North Taluk, Bangalore-560058, India  
Tel: +91-80-23440018/23440019  
Fax: +91-80-23440017  
E-mail: indiasales@leoch.com



[Http://www.leoch.com](http://www.leoch.com)

© 2022 LEOCH. All rights reserved.

Trademarks and logos are the property of LEOCH and its affiliates unless otherwise noted.  
Subject to revisions without prior notice.

Publication No.: LB-LHR12255W-PD-EN-V1.4-202204